

Performance Curve

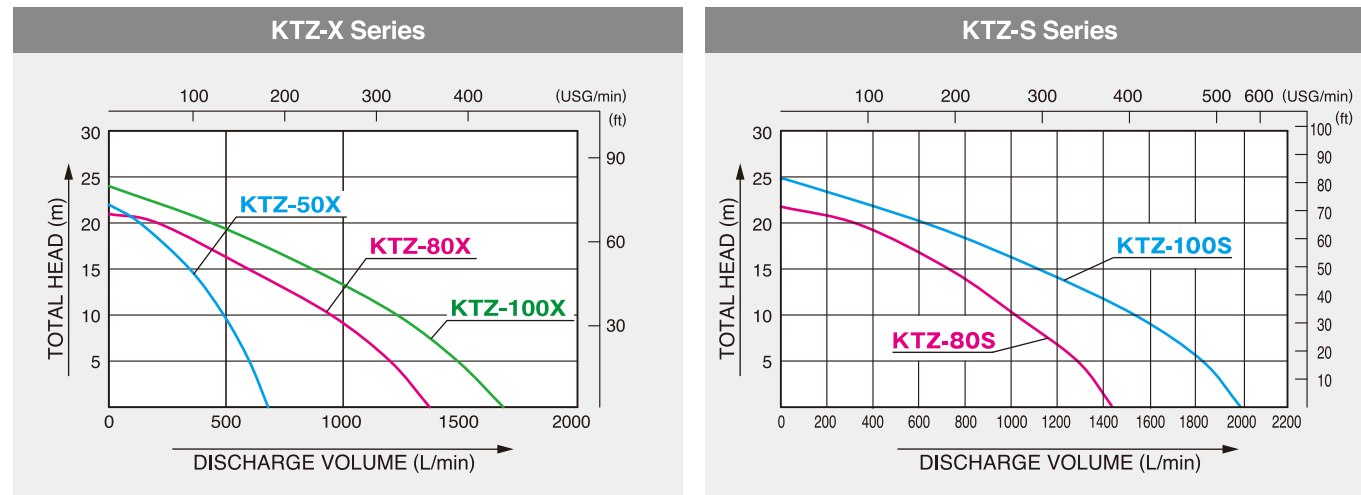

Specifications

MODEL		KTZ-50X	KTZ-80X	KTZ-100X	KTZ-80S	KTZ-100S
PUMP	Connection dia	50 mm(2")	80 mm(3")	100 mm(4")	80 mm(3")	100 mm(4")
	Connection thread	Outer Pipe Thread BSP or NPT				
	Total head	22m (72 ft)	21 m (68 ft)	24 m (78 ft)	22 m (72 ft)	25 m (82 ft)
	Discharge volume	680 L/min (179 USG/min)	1370 L/min (361 USG/min)	1680 L/min (443 USG/min)	1420 L/min (375 USG/min)	1980 L/min (523 USG/min)
	Max. suction lift	8m (26 ft)				
	Material for mechanical seal	Sic (Silicon Carbide) × Sic				
	Material for impeller	Hi-Chrome				
	Material for volute	FCD450				
ENGINE	Type	Forced Air-Cooled 4-stroke Gasoline Engine				
	Model	Koshin K180	Koshin K300	Koshin K420	Koshin K300	Koshin K420
	Displacement	179cc	301cc	420cc	301cc	420cc
	Rated output	3.1 kW (4.2PS) / 3600 rpm	5.0 kW (6.8 PS) / 3600 rpm	7.2 kW (9.8 PS) / 3600 rpm	5.0 kW (6.8 PS) / 3600 rpm	7.2 kW (9.8 PS) / 3600 rpm
	Max. output	3.5 kW (4.8PS) / 3600 rpm	6.0 kW (8.2 PS) / 3600 rpm	8.6 kW (11.7 PS) / 3600 rpm	6.0 kW (8.2 PS) / 3600 rpm	8.6 kW (11.7 PS) / 3600 rpm
	Fuel	Automotive Unleaded Gasoline				
	Fuel tank capacity	3.6 L (0.95 USG)	5.9 L (1.5 USG)	5.9 L (1.5 USG)	5.9L (1.5 USG)	5.9L (1.5 USG)
	Continuous operating time	Approx. 2.0 hrs	Approx. 2.0 hrs	Approx. 1.5 hrs	Approx. 2.0 hrs	Approx. 1.5 hrs
	Starting method	Recoil Starter				
	Standard accessories	1 Strainer, 3 Hose Bands, 1 Engine Tool Set, 1 Multi Tool Wrench (BSP Type: 2 Hose Couplings)				
Net weight	48.1 kg (106.0 lbs)	61.6 kg (135.8 lbs)	78.2 kg (172.4 lbs)	65.3 kg (144.0 lbs)	81.2 kg (179.0 lbs)	
Gross weight	54 kg (119 lbs)	68.4 kg (150.8 lbs)	88.0 kg (194.0 lbs)	72.6 kg (160.1 lbs)	90.5 kg (199.5 lbs)	
Dimensions L×W×H (mm)	703 × 579 × 542	726 × 579 × 603	816 × 621 × 632	729 × 589 × 602	800 × 621 × 624	
Packing unit	1	1	1	1	1	

Heavy Duty Trash Pump

Suitable for use with sandy and muddy water

KTZ series

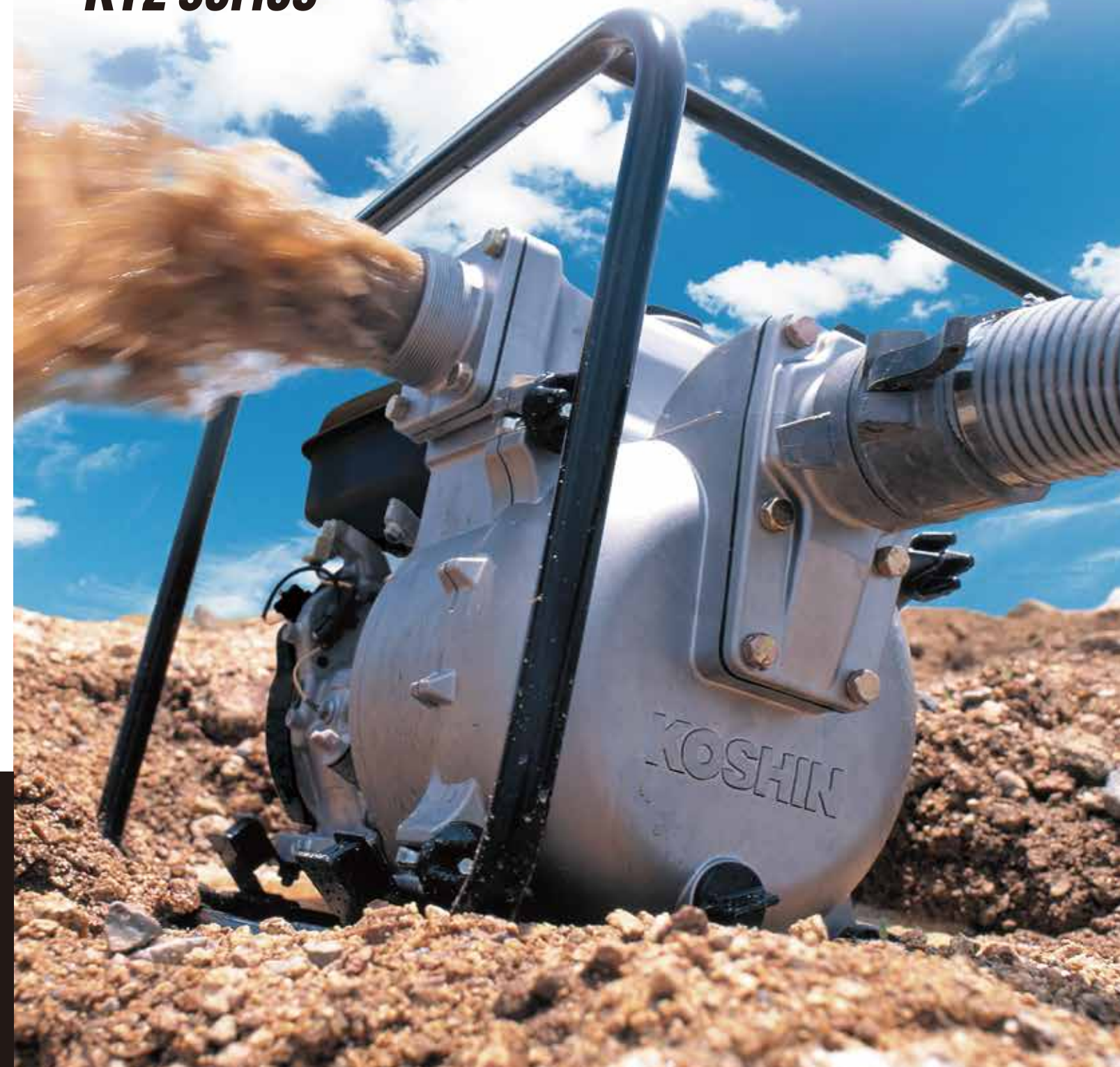

KOSHIN LTD.

12 Kami-Hachinotsubo, Kotari
Nagaokakyo city, Kyoto,
617-8511, Japan

✉ Info@koshin-ltd.co.jp

🌐 www.koshinpump.com



SPECIALLY DESIGNED FOR USE WITH SANDY AND MUDDY WATER

KTZ TRASH PUMP is a highly durable pump specially designed for heavy-duty use on construction sites and suitable for water containing solids. When operating with water containing solids, regular maintenance is required. With the convenient design for maintenance, you can easily clean, repair and shorten down time.

X-TYPE



S-TYPE





Comparison of Specifications

Connection dia	Type	Total head	Discharge volume	Engine
50mm	X	22m	680L/min	KOSHIN K180
80mm	X	21m	1370L/min	KOSHIN K300
	S	22m	1420L/min	KOSHIN K300
100mm	X	24m	1680L/min	KOSHIN K420
	S	25m	1980L/min	KOSHIN K420

Solid Sizes

Max. 20mm Max. 27mm

KTZ-50X KTZ-80X
KTZ-100X
KTZ-80S
KTZ-100S



DURABLE MATERIALS

Made from durable materials that can resist sandy and muddy water

Special Material for Koshin Trash Pumps

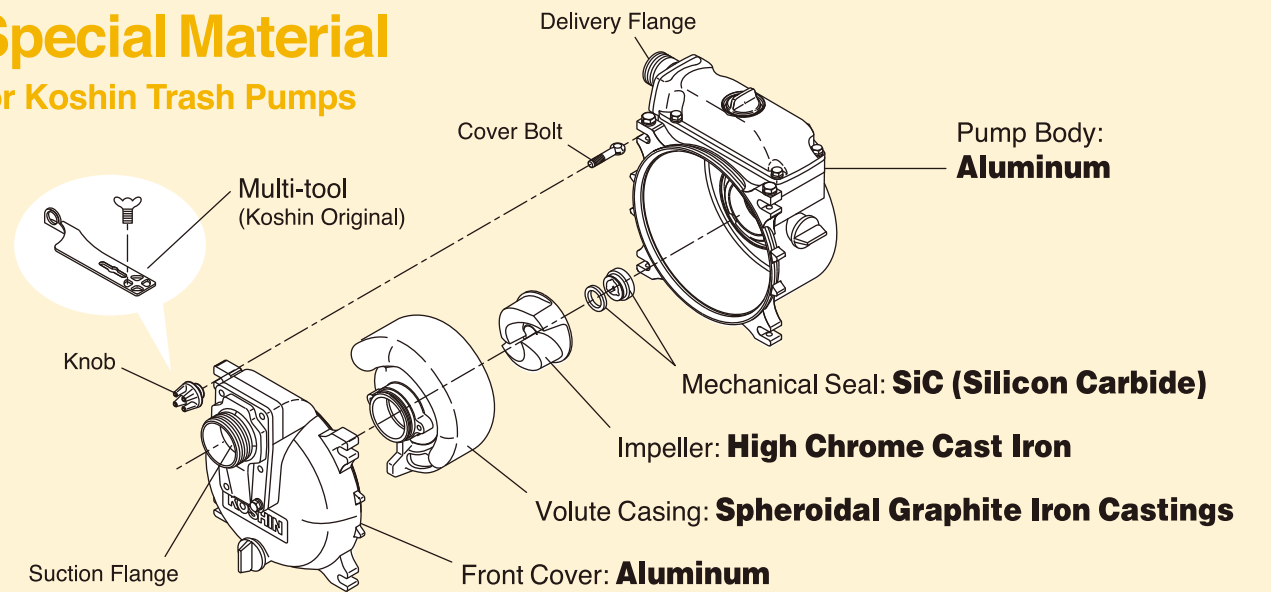

SPECIAL FEATURES FOR S-TYPE

Point 1 Easy removal of impeller with a hex bolt



Point 3 Handle of front cover can be placed either horizontally or vertically



Point 2 Can remove front cover with a standard accessory, multi-tool



Point 4 Front cover can be opened without removing any hoses

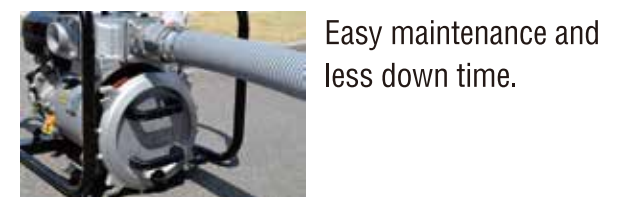

Point 5 Lifting eye

